

ORDINANCE NO. 2013- 40

ORDINANCE AMENDING 2004-25, AS AMENDED, ENTITLED, AN ORDINANCE ADOPTING THE CENTER CITY REDEVELOPMENT PLAN CONSISTENT WITH RESOLUTION 6049 OF THE PLANNING BOARD OF THE CITY OF VINELAND REGARDING THE MAIN STREET DISTRICT OUTDOOR DINING AND SEATING DESIGN STANDARDS.

WHEREAS, on March 23, 2004, the City of Vineland adopted Ordinance 2004-25, An Ordinance Adopting the Center City Redevelopment Plan consistent with Resolution 5203 of the Planning Board of the City of Vineland; and

WHEREAS, the City Council acknowledges that a Redevelopment Plan is meant to be an evolving plan subject to amendment from time to time consistent with the interest to revitalize the Center City area; and

WHEREAS, Main Street Vineland, the Vineland Downtown Improvement District (VDID), has suggested that City Council consider a standard for Main Street Vineland Outdoor Dining and Seating as the goals of the VDID is to create an entertainment destination and the creation of downtown seating would foster pedestrian traffic; and

WHEREAS, the VDID has recognized that while outdoor dining is a benefit, a lack of enforceable standards for appearance and maintenance could lead to unsightly, unsafe conditions in seating areas thus negating any appreciable benefit they may have to provide for the revitalization of Landis Avenue; and

WHEREAS, the Planning Board adopted Resolution No. 6049, Resolution of Findings and Conclusions and Decision of the Vineland Planning Board; and

WHEREAS, the City Council hereby adopts and incorporates by reference the Findings and Conclusions and Decision of the Vineland Planning Board specified in Planning Board Resolution No. 6049; and

WHEREAS, City Council finds it in the best interest of the City to adopt Design Standards for Main Street District Outdoor Dining and Seating consistent with Resolution No. 6049.

NOW, THEREFORE, BE IT ORDAINED by the City Council of the City of Vineland as follows:

1. The Main Street District Outdoor Dining and Seating Design Standards to the Center City Redevelopment Plan as attached hereto are incorporated by reference into this Ordinance.
2. In accordance with the Main Street District Outdoor Dining and Seating Design Standards there is hereby re-established a Design Committee which shall function in accordance with the Main Street District Outdoor Dining and Seating Design Standards.

Passed first reading:

Passed final reading:

President of Council

Approved by the Mayor:

Mayor

ATTEST:

City Clerk



MEMORANDUM



TO: Denise Monaco, Business Administrator
FROM: Yasmin Ricketts, Planning Board Secretary
DATE: July 11, 2012
RE: Amendment to Redevelopment Plan
Center City Outdoor Dining and Seating Design Standards

Enclosed is a signed copy of Resolution #6049 of the Planning Board giving comments on an amendment to the Center City Redevelopment Plan concerning the Center City's Outdoor Dining and Seating Design Standards.

YR/
Encl.
xc: Keith Petrosky, City Clerk
Richard Tonetta, City Solicitor
Alex Curio

RESOLUTION NO. 6049
RESOLUTION OF FINDINGS AND CONCLUSIONS AND
DECISION OF THE VINELAND PLANNING BOARD

WHEREAS, the Planning Board of the City of Vineland has considered a request from the VDID (Vineland Downtown Improvement District), to amend the Center City Redevelopment Plan, specifically to amend the Center City Redevelopment Plan so as to include “Main Street District Outdoor Dining and Seating Design Standards”; and

WHEREAS, the Planning Board considered the presentation of Kathleen Hicks, Supervising Planner, City of Vineland, at which time Ms. Hicks noted the following:

- a) The proposed amendment to the Center City Redevelopment Plan is requested by VDID.
- b) “Main Street” has design standards and guidelines adopted as amendments to the Redevelopment Plan.
- c) The guidelines also require a Design Committee.
- d) The Design Committee should be reestablished for the “Design Guidelines”.
- e) Also, the Design Committee is required for the proposed outdoor dining and seating design standards.

NOW, THEREFORE, BE IT RESOLVED, by the Planning Board of the City of Vineland, that recommendation is made to City Council of the City of Vineland, to adopt the Main Street District Outdoor Dining and Seating Design Standards to the Center City Redevelopment Plan, attached hereto and incorporated by reference into this resolution.

Recommendation is also made to City Council to reestablish the Design Committee required for the Main Street Design Guidelines and the Outdoor Dining and Seating Design Standards. Attached hereto and incorporated by reference into this resolution.

The foregoing is a true copy of the Resolution and decision adopted by the Planning Board of the City of Vineland at its meeting held on June 12, 2013, as reflected in the recorded minutes of the said meeting.

ADOPTED DATE: 6/26/13

PLANNING BOARD OF THE
CITY OF VINELAND

YASMIN RICKETTS, Secretary

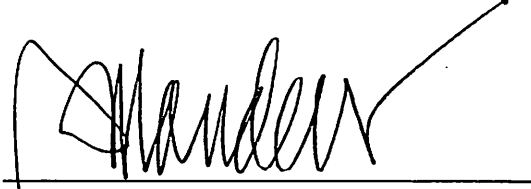
DAVID MANDERS, Chairperson

ROLL CALL VOTE

VOTING IN FAVOR

- STEVEN PLEVINS
- MARIA PEREZ
- DAVID MAZUR
- SANDY VELEZ
- RYAN HEADLEY
- MICHAEL PANTALIONE
- JOHN CASADIA
- DAVID MANDERS

ABSTAINING

NONE

ABSENT

- ANGELA CALAKOS
- BONNIE RIVERA

OPPOSED

NONE

Main Street District
Outdoor Dining and Seating
Design Standards

City of Vineland
March 2013

Portions supplied by City of Alexandria, VA

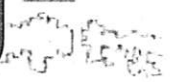
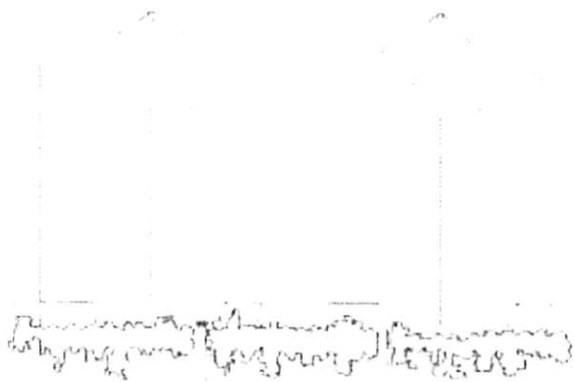

Table of Contents

Purpose		3
Background		4
Application Procedure		5
Elements of a Quality Outdoor Seating Area		6
Chapter 1: Barriers		7-15
1.1 Barrier Designs	8	
1.2 Access Openings	12	
1.3 Barrier Measurements	13	
1.4 Planters	14	
Chapter 2: Furniture and Fixtures		16-25
2.1 Types of Furniture	17	
2.2 Tables	18	
2.3 Chairs	20	
2.4 Umbrellas	21	
2.5 Sidewalk Coverings	23	
2.6 Circulation Room	24	
2.7 Signage	24	
2.8 Lighting	24	
2.9 Setback from Other Businesses	25	
3.0 Maintenance	25	
3.1 Storage and Security During Off-Hours	25	

Purpose

These standards provide parameters for the use of outdoor dining and seating areas along Landis Avenue, including all adjoining side streets as well as Wood and Elmer Street, in order to maintain a quality appearance that keeps with the Main Street District's character.

This document contains the standards of furniture and fixtures considered acceptable within the architectural and cultural framework of the Main Street District.

Central to the process of permitting outdoor dining and seating within the Main Street District is the necessity of ensuring that furniture and other items placed along the street will complement the overall character of the street and not detract from the district's architectural heritage. These Design Standards provide parameters for the use of outdoor dining and seating areas in order to enhance the character, visual quality and pedestrian safety of the area.

These standards apply to all outdoor dining and seating areas in the designated Main Street District. Applicants must receive preliminary approval from Main Street Vineland's Design Review Subcommittee, and final approval from the City of Vineland. Failure to comply with these standards constitutes a violation of city regulations.

Background

The Vineland Main Street District is pleased to offer restaurants and other businesses in the district the option of utilizing the privately-held portion of their sidewalk as outdoor dining or seating areas. Outdoor dining and seating give business patrons an amenity that has become an increasingly popular feature in downtowns across the nation.

While the Main Street District has encouraged the use of outdoor dining and seating arrangements, restaurant operators must be mindful of two important considerations: safety and flow of pedestrian traffic, and the visual appropriateness within the district.

These Outdoor Dining and Seating Standards are intended to ensure that businesses use the private sidewalks for outdoor dining and seating in a way that is both safe for pedestrians and appropriate for the district.

Application Procedure

Outdoor dining and seating is permitted in the district through an administrative approval process authorized by the Design Review Subcommittee of Main Street Vineland and the City of Vineland Zoning Office. This administrative process saves time and expense by pre-establishing standards that must be followed for all outdoor dining and seating set-ups.

To apply, an applicant needs to complete the following:

- **Application Form:** A brief form with basic information about the restaurant and proposed number of seats and property lines.
- **Diagram:** A to-scale plan showing the proposed outdoor dining or seating area with measurements (including a representation showing that public sidewalks will remain for pedestrians).
- **Photos or Drawing of Furniture:** Photos or other graphic representation (including color and material) of furniture and umbrellas, needed for the Design Review Subcommittee to verify that the proposed furniture conforms to the Outdoor Dining and Seating Standards.

For forms, information or questions, contact Main Street Vineland at (856) 794-8653 or visit in person at 603 E. Landis Avenue.

Elements of a Quality Outdoor Seating Area



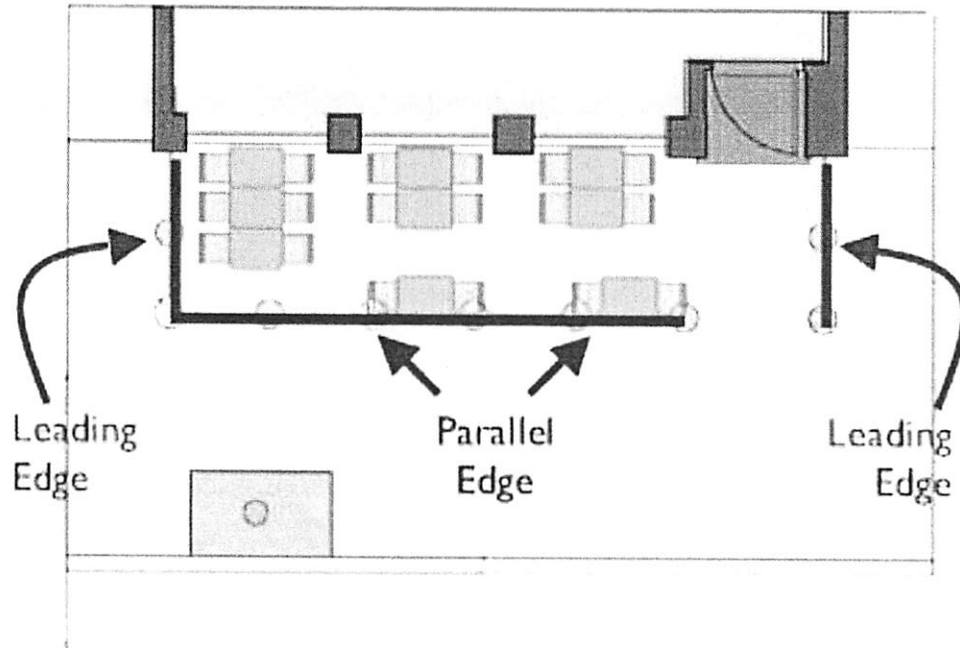

FIGURE 1
Illustration of leading edge and parallel edge of barrier

Chapter 1: Barriers

Dining and seating area barriers (fences, ropes etc.) are visually appealing and help to separate the dining or seating area from the sidewalk. All barrier material must be maintained in good visual appearance, without visible fading, dents, tears, rust, corrosion, or chipped or peeling paint.

In some cases, barriers are optional; however, if a business plans on having them as part of their outdoor dining or seating, they must comply with these standards.

Barriers are required in the following instances:

- a) Required for Leading Edge of All Dining or Seating Areas:** A detectable barrier is required for the leading edge of all outdoor dining and seating areas to ensure that visually-impaired pedestrians using canes can detect the dining or seating area safely. The *leading edge*, illustrated at left, is defined as the section of a dining or seating area that is at or near a perpendicular angle to the building wall and/or curb line. There is a 6-inch maximum for spacing from the façade for the leading edge of a barrier.
- b) Required for Full Perimeter of Some Dining or Seating Areas:** A detectable barrier is required for the full perimeter (with the exception of access openings). The perimeter includes both the leading edge and parallel edge.
- c) Required for Full Perimeter of All Outdoor Dining Areas Serving Alcohol:** State law requires that outdoor dining areas where alcohol is served or consumed must enclose the area, with only one opening to the sidewalk for access.



FIGURE 2
Acceptable sectional fencing design

1.1 Barrier Design

A wide variety of styles and designs are permissible for outdoor dining and seating area barriers.

Sectional Fencing: Sectional fencing (generally defined as rigid fence segments that can be placed together to create a unified fencing appearance) is a desirable solution for outdoor dining and seating areas using barriers. Such fencing is portable, but cannot be easily shifted by patrons or pedestrian, as can less rigid forms of enclosures.

Sectional fencing must be of metal (aluminum, steel, iron, or similar) or of wood construction and must be of a dark color (either painted or stained).

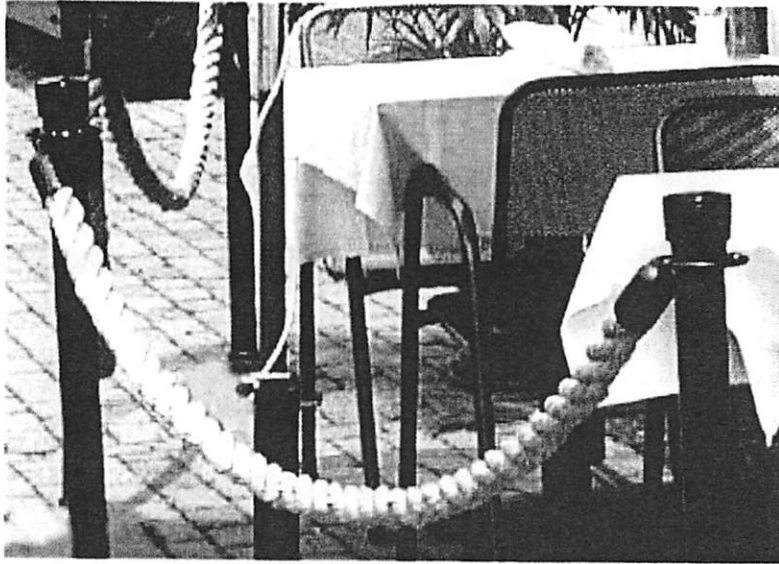

FIGURE 3
Rope or chain barrier must have a minimum diameter of 1 inch



FIGURE 4
Stanchion base must be flat and no more than 1/2" above sidewalk surface



FIGURE 5
Domed stanchion bases are not permitted

1.1 Barrier Design (cont'd)

Rope or Chain Rails: Rope or chain-type barriers (generally defined as enclosures composed of a rope or chain suspended by vertical elements such as stanchions) are permitted if they meet the following guidelines:

- Rope/Chain Diameter:** The rope or chain must have a minimum diameter of 1 inch, in order to maintain detectability by the visually-impaired.
- Posts:** Vertical support posts (stanchions, bollards, etc.) must be constructed of wood or metal (aluminum, steel, iron, or similar).
- Stanchion Base Must Not Be a Tripping Hazard:** If a stanchion or other vertical supporting device is attached to a base, that base must be flat and must measure no more than one-half (1/2) of an inch above the sidewalk surface. No domed stanchion bases are permitted.

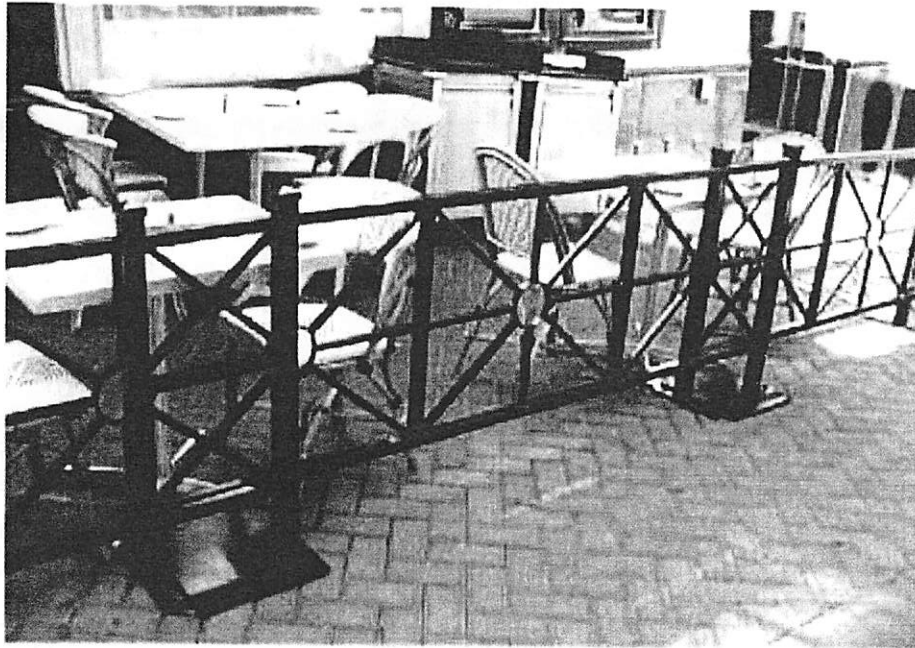

FIGURE 6
Acceptable sectional fencing design: freestanding

1.1 Barrier Design (cont'd)

Freestanding: Any barrier (whether sectional Fencing or rail-type) must be freestanding, without any permanent or temporary attachments to buildings, sidewalks or other infrastructure.

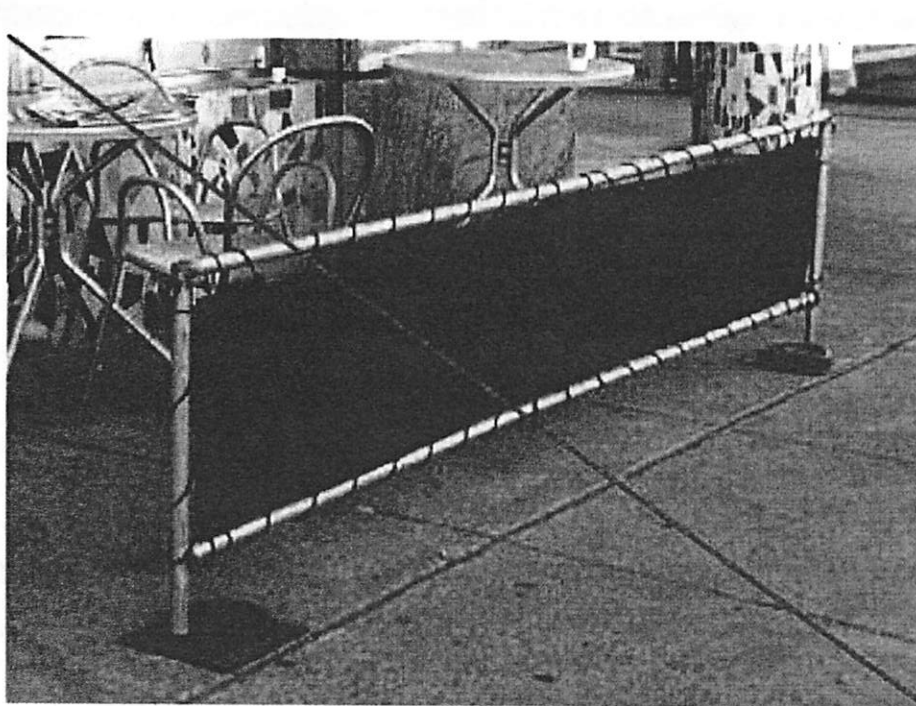

FIGURE 7
Fabric inserts are not permitted to be used as part of a barrier

1.1 Barrier Design (cont'd)

A wide variety of styles and designs are permissible for outdoor dining and seating area barriers.

Prohibited Barrier Styles:

- **Fabric Inserts:** Fabric inserts (whether natural or synthetic fabric) of any size are not permitted to be used as part of a barrier.
- **Chain-link, Vinyl and Other Fencing:** The use of chain-link, vinyl, cyclone fencing, chicken wire or similar appurtenances is prohibited. Materials not specifically manufactured for fencing or pedestrian control (including but not limited to buckets, food containers, tires, tree stumps, vehicle parts, pallets, etc.) and not expressly permitted elsewhere in these standards may not be used as components of a barrier.



FIGURE 8
Sectional fencing barrier height must be at least 36"

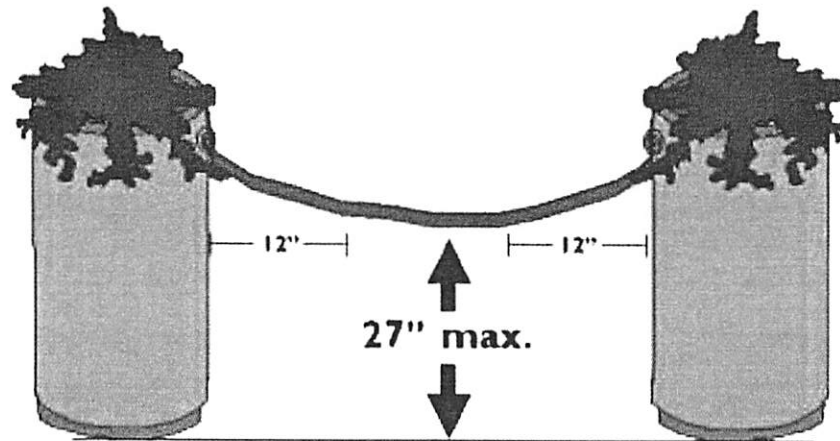

FIGURE 9
How to measure rope/chain distance from ground

1.2 Access Openings

Height: The highest point of a barrier (such as a stanchion) must measure at least 36 inches in height, with the exception of planters.

"Open" Appearance: Fences or other perimeter enclosures with a height of between 36 inches and 50 inches must be at least 50% open (see-through) in order to maintain visibility of street level activity. Any enclosure with a height over 50 inches be at least 80% open (see-through).

Maximum Distance from Ground: All barriers must be detectable to visually-impaired pedestrians who employ a cane for guidance. Therefore, the bottom of barriers must be no greater than 27 inches above the sidewalk surface.

•How to Measure Rope/Chain Distance from Ground: In the case of a rope or chain enclosure, the rope/chain must not exceed 27 inches in height when measured 12 inches or more away from a vertical post (stanchion, bollard or other such support).

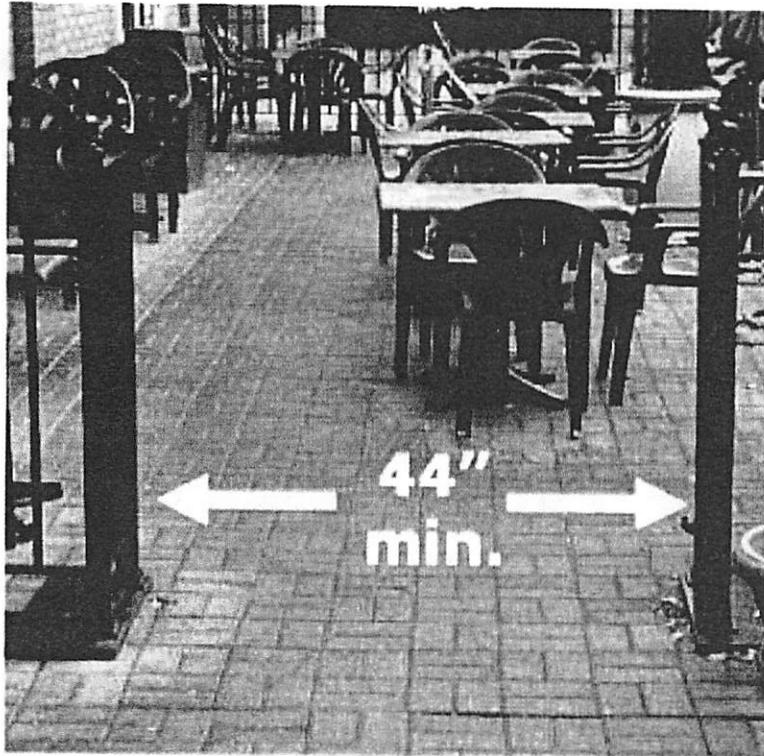

FIGURE 10
Minimum access width is 44 inches

1.3 Barrier Measurements

To ensure the effectiveness as pedestrian control devices and their detectability for persons with visual impairments, barriers must meet the following measurement guidelines:

Minimum Access Width: Any access opening within the barrier must measure no less than 44 inches in width.

Location: Access openings should be placed in a location that will not create confusion for visually impaired pedestrians.

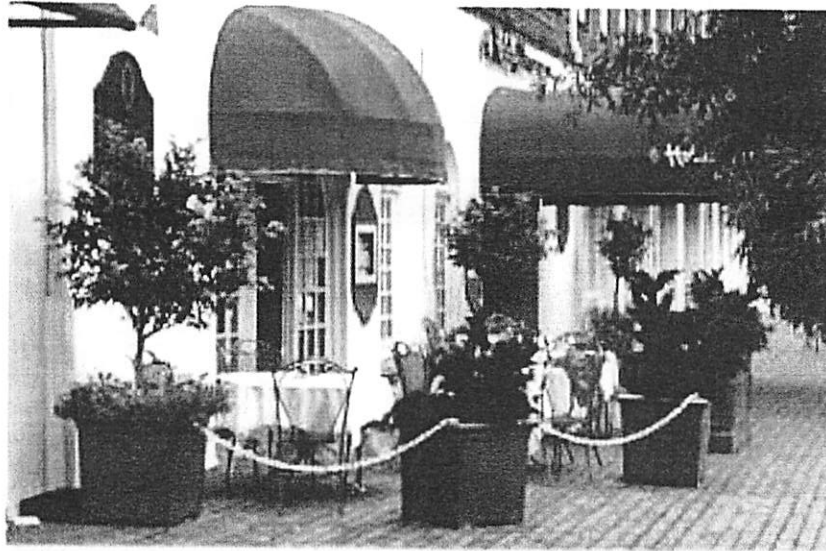

FIGURE 11
*Acceptable planter design
and material*



FIGURE 12
*Height of plants
may not exceed 8'*

1.4 Planters

Planters may be used in addition to or in place of other barrier designs, in order to provide added visual interest and create a more attractive and welcoming atmosphere.

Planters and the plants contained within them must meet the following requirements:

Maximum Height of Planters: Planters may not exceed a height of 36 inches above the level of the sidewalk (this pertains only to planters and not the plants contained therein). Planters may be made of recycled material but prior approval by the Design Review Committee is required.

Maximum Height of Plants: Plants must allow for 80% visibility if over 50 inches high, and may not exceed a height of 108 inches (8 feet) above the level of the sidewalk.

Extension of Plants: Vegetation must not extend beyond the approved boundaries of the outdoor dining or seating area.

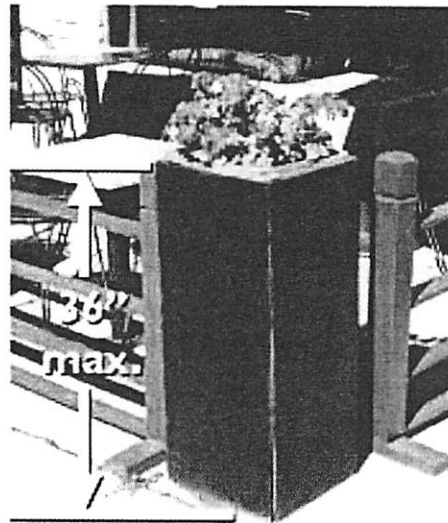
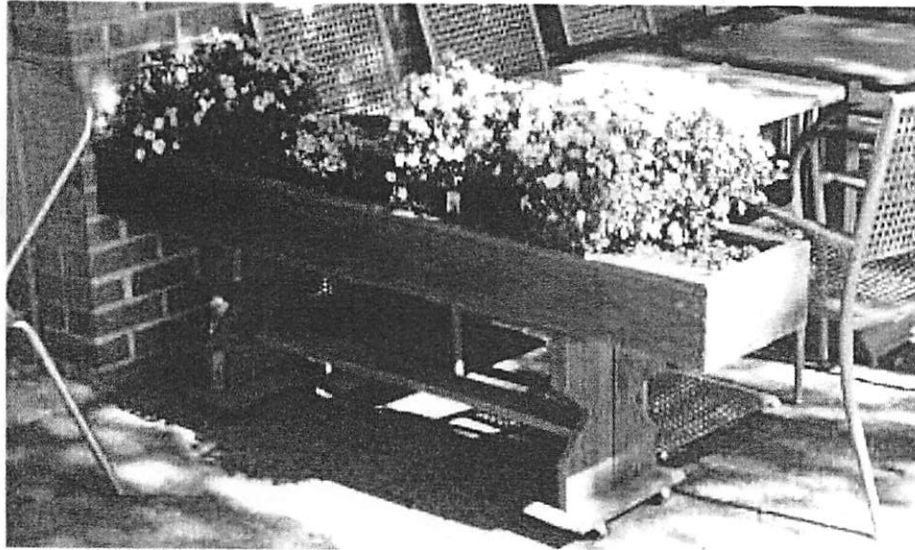

*FIGURES 13, 14 and 15
Acceptable planter design and material*

1.4 Planters (cont'd)

Planted Material: All planters must have plants contained within them. If the plants within a planter die, the plants must be replaced or the planter removed. Artificial plants, empty planters, or planters with only bare dirt, mulch, straw, woodchips or similar material are not permitted.

Seasonal, thematic planter displays are encouraged

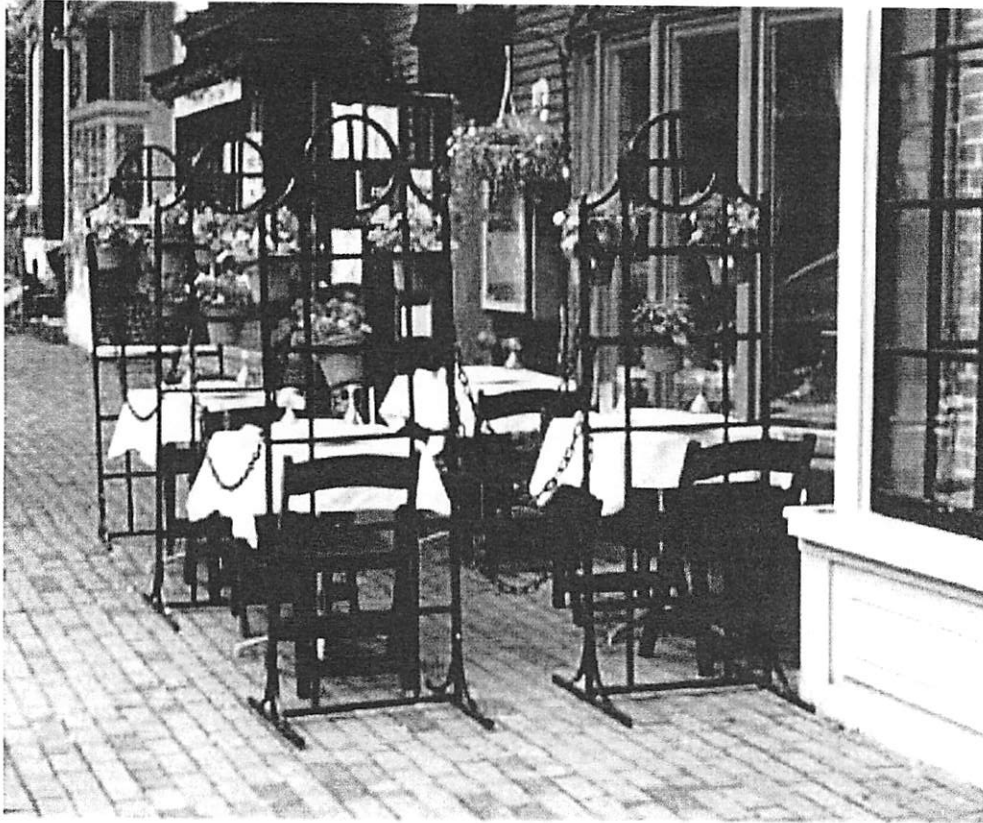

Chapter 2: Furniture and Fixtures

The Main Street District's retail liveliness depends on maintaining an attractive and high-quality atmosphere.

Outdoor dining and seating furniture becomes a prominent part of the streetscape when used in the front of buildings, and such furniture needs to uphold the high standards applied to buildings and other improvements the Main Street District.

A wide range of furniture styles, colors and materials are permitted. All furniture and fixtures must be maintained in good visual appearance, without visible fading, dents, tears, rust, corrosion, or chipped or peeling paint. All furniture and fixtures must be maintained in a clean condition at all times. All furniture and fixtures must be durable and of sufficiently sturdy construction so as not to blow over with normal winds.

To ensure a quality visual appearance in keeping with the Main Street District, the conditions on the following pages apply to furniture (tables, chairs and benches).

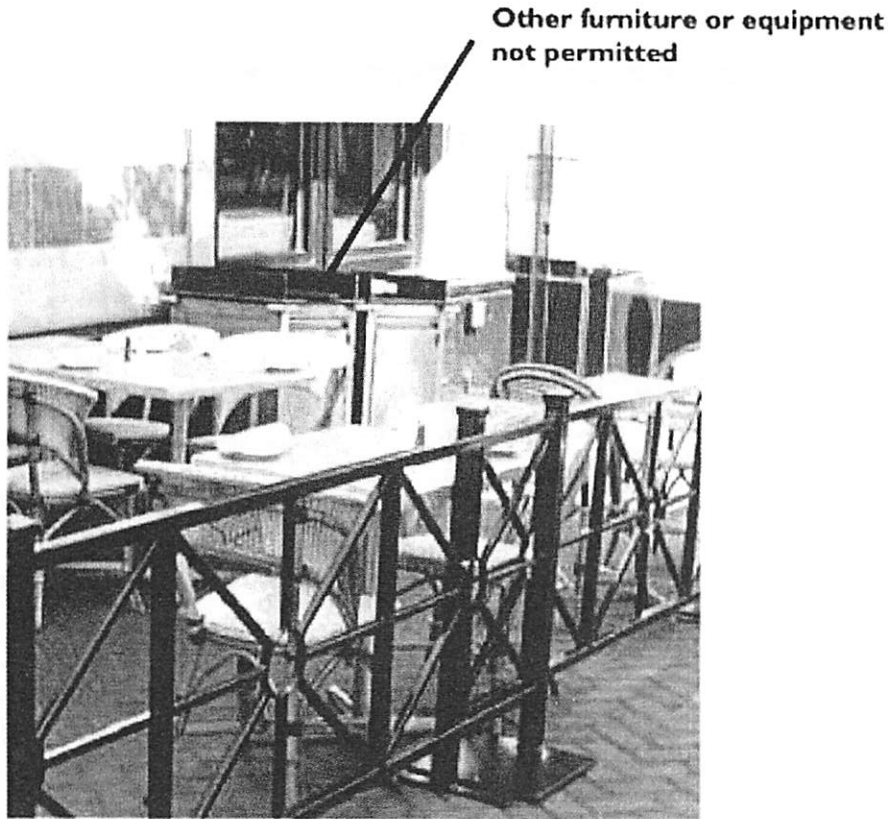

FIGURE 16
Furniture other than tables, chairs and umbrellas is not permitted

2.1 Types of Furniture

Prohibited Furniture: All furniture other than tables, chairs, benches and umbrellas is prohibited. This includes but is not limited to serving stations, bar counters, shelves, racks, sofas, televisions, trash receptacles and torches. Heaters are permitted with pre-approval from the city's Fire Marshal's office. Plastic furniture is generally not permitted.

Freestanding: Furniture and fixtures must not be secured to trees, lampposts, street signs, hydrants, or any other street Infrastructure by means of ropes, chains or any other such devices, whether during restaurant operating hours or at times when the restaurant is closed.

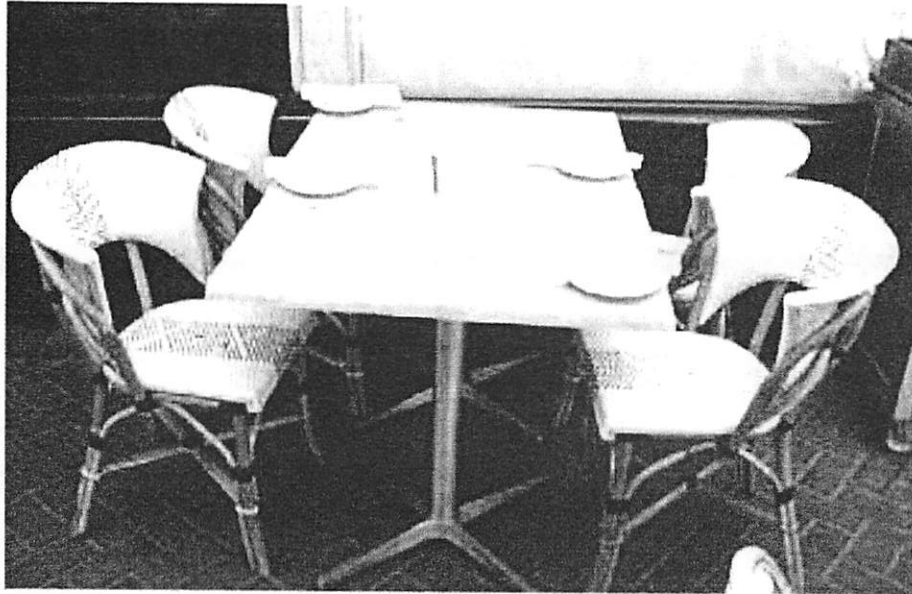

FIGURE 17
Furniture may be of dark color or natural unpainted material

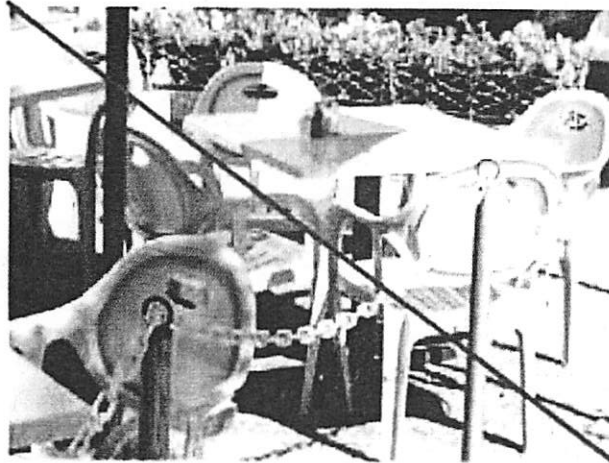

FIGURE 18
No white or fluorescent furniture is permitted

2.2 Tables

Outdoor dining and seating furniture must also contribute to the overall atmosphere of the Main Street district and be complementary in both appearance and quality.

Color: Tables may be colored or of a natural unpainted material (i.e., wood, metal etc.). Colors must be approved by the Design Review Subcommittee.

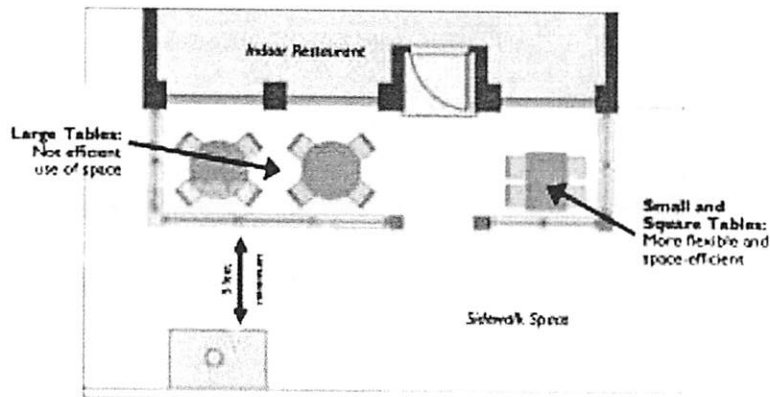
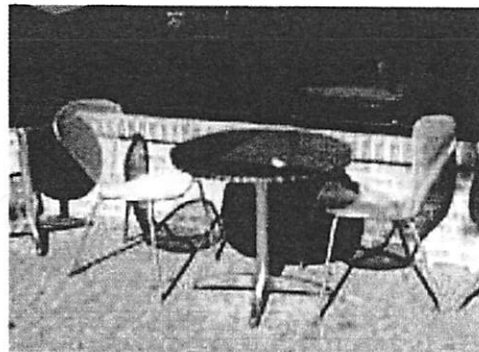

FIGURE 19
Efficient furniture layout - smaller furniture works better on King Street



FIGURES 20 and 21
Smaller bistro-style tables are more efficient for use along King Street

2.2 Tables (cont'd)

Size and Shape: The size and shape of tables strongly affects the functionality of an outdoor dining or seating area.

Square or Rectangular Tables Preferred: Square or rectangular tables are strongly recommended.

- **Better Fit:** Square or rectangular tables may fit flush against a building's wall and can permit more usable surface area for patrons while at the same time leaving more space available for pedestrians.

- **More Flexibility:** Square or rectangular tables are more flexible for use in outdoor dining or seating areas. Such tables may be combined to seat larger parties much more effectively than can round tables.

Smaller Tables Preferred: Smaller tables work better than larger tables and are more efficient and flexible. Although optimal table size varies by each business' specific outdoor dining or seating layout, smaller tables are preferred.

Consistency: All tables within a particular establishment's outdoor dining or seating area must match each other by being of visually-similar or -complementary design, construction and color.



FIGURE 22
Chairs used in an outdoor dining area must match each other



FIGURE 23
No white plastic or fluorescent furniture is permitted



FIGURE 24
Furniture may be of dark color or natural unpainted material

2.3 Chairs

Chairs, like other outdoor dining and seating elements, must contribute to the overall atmosphere of the Main Street District and must be complementary in both appearance and quality.

Color: Chairs may be colored or of a natural unpainted material (i.e., wood, metal etc.). Chairs are not permitted to be plastic or of any fluorescent or other strikingly bright or vivid color. Colors must be approved by the Design Review Subcommittee.

Upholstery: Upholstered chairs are permitted. Upholstery is not permitted to be of any fluorescent or other strikingly bright or vivid color. Colors must be approved by the Design Review Subcommittee.

Consistency: All chairs used within a particular establishment's outdoor dining or seating area must match each other by being of visually-similar design, construction and color.

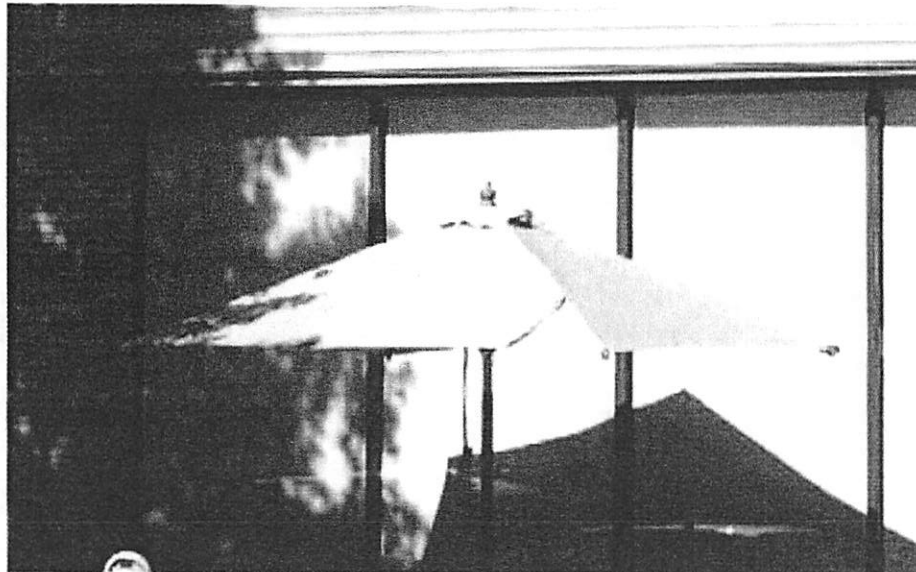

FIGURE 25
Acceptable umbrella design

2.4 Umbrellas

Umbrellas can add a welcoming feel to outdoor dining and seating areas and provide shelter from the elements, making their use desirable for outdoor dining and seating applications. Appropriately- designed and -sized umbrellas are permitted for use under this outdoor dining and seating program. Umbrellas must be contained within the outdoor dining or seating area, and the lowest dimension of an extended umbrella must be at least 7 feet above the sidewalk surface. All umbrellas must comply with the following conditions.

Contained Within the Outdoor Seating Area:

To ensure effective pedestrian flow, all parts of any umbrella (including the fabric and supporting ribs) must be contained entirely within the outdoor dining or seating area.

Minimum Height for Sidewalk Clearance:

When extended, the umbrella must measure at least 7 feet above the surface of the outdoor dining or seating area in order to provide adequate circulation space below. This measurement must include not only the umbrella frame and panels, but also any decorative borders such as fringes, tassels, or other such ornamentation.

Maximum Height: Any part of an umbrella used in an outdoor dining or seating area may not exceed a height of 120 inches (10 feet) above the level of the sidewalk, in order to avoid causing an undue visual obstruction of other businesses.



FIGURE 26
Acceptable umbrella design: Solid color, space-efficient, market-style, canvas material

2.4 Umbrellas (cont'd)

Colors: Umbrellas must blend appropriately with the surrounding built environment. Colors must be approved by the Design Review Subcommittee.

Size and Shape: The size and shape of an umbrella strongly affects its functionality within a constrained space such as an outdoor dining or seating area. Due to the narrow measurements of most establishments' outdoor dining or seating areas, businesses using umbrellas should strive for space-efficient umbrella designs.

Square or Rectangular Umbrellas Preferred: Square or rectangular umbrellas, as opposed to round or octagonal umbrellas, are strongly recommended for use in the Main Street District's outdoor dining or seating areas.

Market-Style Umbrellas Preferred: Market-style umbrellas — those designed specifically for patio or outdoor restaurant use — are preferred for outdoor dining or seating purposes.

Material: Umbrella fabric must be of a material suitable for outdoor use, and must be canvas-type. No plastic fabrics, plastic/vinyl-laminated fabrics, or any type of rigid materials are permitted for use as umbrellas within an outdoor dining or seating area.

General: Umbrellas must be sufficiently anchored to withstand windy conditions. Additionally, umbrellas must be closed and secured after business hours.



FIGURE 29
Outdoor dining areas should be uncovered sidewalk material

2.5 Sidewalk Covering

The floor of outdoor dining or seating areas should be uncovered sidewalk material so as to provide continuity with the adjacent public right-of-way. Floor coverings or raised platforms may not be used within outdoor dining or seating areas.

2.6 Circulation Room

If a perimeter enclosure is used, adequate space must be provided within the enclosed outdoor dining or seating area to permit movement of patrons and wait staff. Wait staff may not serve patrons from beyond the perimeter enclosure.

2.7 Signage

Signage is permitted within outside dining or seating areas only with a valid City permit. No extra or additional signage is permitted solely as a result of an establishment's participation in this outdoor dining and seating program.

2.8 Lighting

Lighting on barriers is permitted if the intent is to add a festive, decorative element and not to attract attention. Lighting shall be white or clear in color and shall be understated, and flashing or blinking lights are not permitted. Light strands shall be kept in good repair and burned out bulbs shall be replaced.



FIGURE 31
Neighboring businesses must remain visible to pedestrians and motorists

2.9 Setback from Other Businesses

Restaurants need to be mindful of adjoining businesses when using outdoor dining areas, making sure that neighboring businesses remain visible to pedestrians and motorists.

A restaurant may be required to adjust the outdoor seating area's layout, dimensions or distance from the property line (2 feet or more) to ensure that this visibility is maintained.

3.0 Maintenance

Owners/operators shall be responsible for maintaining barriers, furnishings and lighting in such a manner that they present a high-quality image.

Any barriers, furnishings or lighting showing signs of wear, damage or failure must be promptly refurbished, repaired or replaced.

3.1 Storage and Security During Off-Hours

All furniture, barriers and umbrellas that will not be in use for more than 48 consecutive hours must be removed and appropriately stored off of the sidewalk.